

CBCS SCHEME

USN

--	--	--	--	--	--	--	--	--	--

15ENG2.5

Second Semester B.Arch. Degree Examination, Dec.2018/Jan.2019 Building Structures – II

Time: 3 hrs.

Max. Marks: 100

Note: Answer FIVE full questions, choosing ONE full question from each module.

Module-1

- 1 a. Define centre of gravity and centroid. (04 Marks)
b. Determine the centroid of I-section shown below in Fig. Q1 (b). (16 Marks)

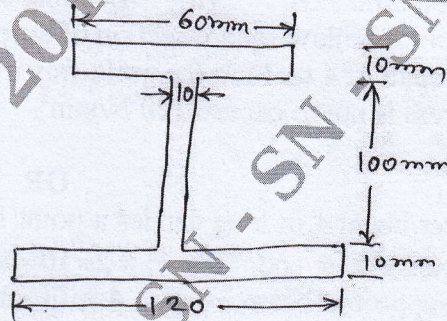

Fig. Q1 (b)

OR

- 2 a. State the parallel axis theorem with sketch. (04 Marks)
b. Determine the M.I of the figure shown in Fig. Q2 (b) about its centroidal axis. (16 Marks)

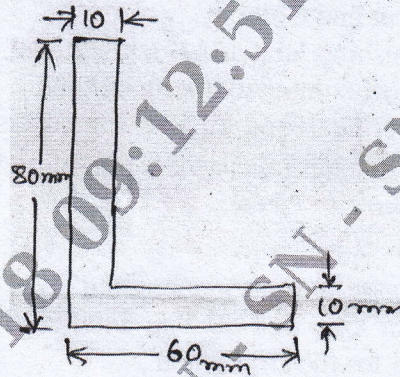

Fig. Q2 (b)

Module-2

- 3 a. Define Shear force and bending moment. (04 Marks)
b. Draw the shear force diagram and bending moment diagram for the beam shown below in Fig. Q3 (b). (16 Marks)

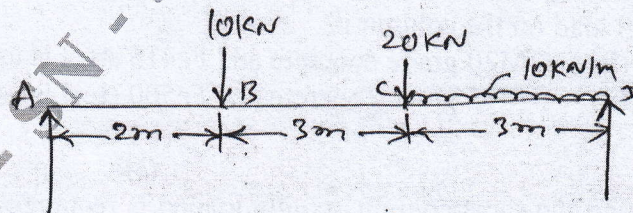

Fig. Q3 (b)

Important Note : 1. On completing your answers, compulsorily draw diagonal cross lines on the remaining blank pages.
2. Any revealing of identification, appeal to evaluator and /or equations written eg, 42+8 = 50, will be treated as malpractice.

OR

- 4 a. What are the types of beams? Draw the sketches. (06 Marks)
 b. What are the types of loads on beam? (04 Marks)
 c. Draw the SFD and BMD for the Cantilever beam shown in Fig. Q4 (c). (10 Marks)

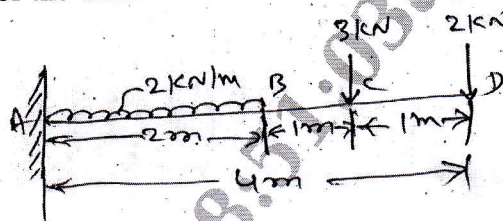

Fig. Q4 (c)

Module-3

- 5 a. Define the following:
 (i) Neutral axis. (ii) Bending stress. (iii) Section modulus. (06 Marks)
 b. A steel beam of hollow square section of outer side 100 mm and inner side 80 mm is used as beam for a span of 4 m. Find the uniformly distributed load on the beam that can carry if the bending stress is not to exceed 120 N/mm^2 . (14 Marks)

OR

- 6 a. A Cantilever beam 4 m long carries a point load of 10 kN at free end. Determine the slope and deflection at free end. Take $E = 2 \times 10^5 \text{ N/mm}^2$. $I = 4000 \times 10^4 \text{ mm}^4$. (10 Marks)
 b. A simply supported beam of span 4 m is carrying a uniformly distributed load of 5 kN/m throughout its span. The size of the beam is $100 \times 200 \text{ mm}$. Find the maximum slope and deflection at mid span, if $E = 1 \times 10^4 \text{ N/mm}^2$. (10 Marks)

Module-4

- 7 a. Define :
 (i) Strut and Column
 (ii) Crushing load and Buckling load.
 (iii) Short column and long column. (12 Marks)
 b. Calculate the critical load for a strut which is made of a bar of circular in section of diameter 40 mm and 5 m length the strut is pin jointed at both ends. Take $E = 1 \times 10^5 \text{ N/mm}^2$. (08 Marks)

OR

- 8 a. What are the assumptions made in the Euler's column theory? (08 Marks)
 b. A strut is 3 m long and 50 mm external diameter and 30 mm internal diameter. Find the crippling load for the strut when
 (i) Strut is fixed at both ends.
 (ii) One end is fixed and other hinged. (12 Marks)
 Take $E = 200 \text{ KN/mm}^2$

Module-5

- 9 A circular column of 400 mm diameter is reinforced with 6 numbers of 16 mm ϕ . Find the axial load on the column if
 (i) M20 grade concrete and Fe415 steel is used.
 (ii) M15 grade concrete and Fe500 steel is used. (20 Marks)

OR

- 10 Design the short column, axially loaded is rectangular column to support a load of 875 kN. One side of the column D restricted to 300 mm. Use M25 concrete and Fe415 steel. (20 Marks)
